

# ALBUM ENTERPRISE

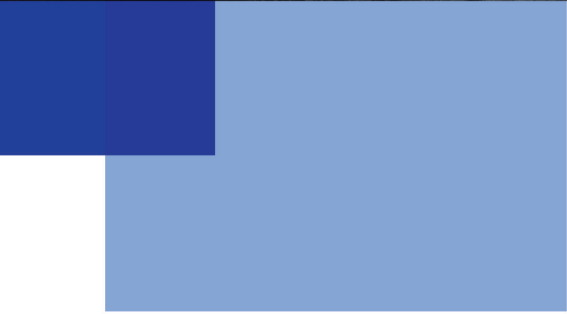

新品发布

---

吴江市永亨铝业有限公司  
COMPANY PROFILE

# Company Profile 公司简介

吴江市永亨铝业有限公司位于太湖之滨苏州市境内，是一家专业生产铝合金建筑型材的大型私营企业。公司创建于1993年，占地面积约10万平方米。主要产品有：阳极氧化型材；电泳涂漆型材；粉末喷涂型材；木纹转印型材；穿条式、浇注式隔热型材等五大类。产品注册商标“亨利”牌。

经过近二十年的奋斗与发展，从质到量我们已拥有让顾客信赖的生产规模，各类铝合金型材年生产能力可达3万余吨，日最高产量100多吨。熔铸生产线拒绝废铝，严把质量第一关！挤压生产线12条。挤压机最大吨位2200吨，能够生产截面尺寸较大的型材产品，基本可以满足国内门窗、幕墙市场的需求。阳极氧化、电泳涂漆生产线的关键工序采用进口生产工艺或生产原料，产品品质具有国际水准。粉末喷涂生产线2条，粉房全套进口，高科技、全自动控制系统，为长期稳定的生产质量奠定了物质基础。隔热型材选用优质尼龙隔热条及进口聚氨酯隔热胶，节能效果显著。

追求一流品质、达到一流服务、创造一流效益、树立一流形象，是永亨人共同的追求！

公司于2001年通过ISO9001国际质量管理体系认证。历年来，在国家、省、市各级质量技术监督部门组织的产品质量监督抽查中从未发生过不合格现象。“亨利”牌铝型材产品不仅在国内畅销，还大量出口德国、日本、美国、澳大利亚、土耳其、乌克兰等十多个国家，在国际国内均享有较高的声誉。近年来，公司在大力开发新产品的同时也非常重视知识产权的保护，“亨利”铝材共申请外观和实用新型专利135项。“亨利”牌铝合金建筑型材产品曾荣获过“国家免检产品”、“江苏名牌产品”、“江苏省著名商标”等荣誉称号！



此作品版权归属为  
南京开图网络科技有限公司

# Catalogue 目录

- 02 50平开普通门窗
- 03 55隔热平开门窗
- 04 65隔热平开门窗
- 05 70隔热推拉门窗
- 06 75折叠门窗
- 07 80隔热推拉门窗
- 08 80普通推拉门窗
- 09 120普通重型推拉门窗
- 10 135隔热窗纱一体
- 11 76隔热平开门窗



Cooperation and win-win  
Bright future

协作共赢 共铸辉煌  
Cooperation and win-win  
Bright future

此作品版权归属为  
南京开图网络科技有限公司



Production System  
生产体系

Production System

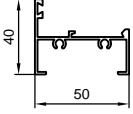
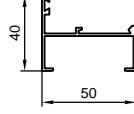
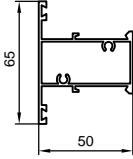
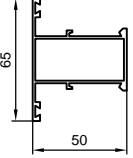
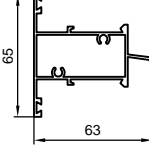
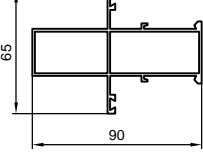
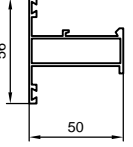
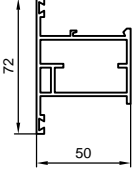
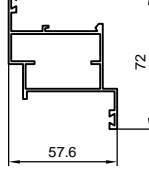
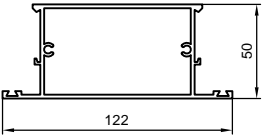
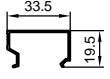

实验室

# 50JF系列平开门、窗型材图

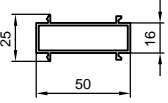
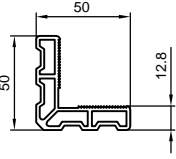
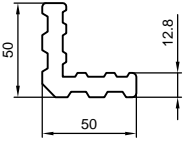
<p><b>50JF101</b></p> <p>横外框</p> <table border="1"> <tr><td>1.40</td><td>0.606kg/m</td></tr> <tr><td>2.00</td><td>0.766kg/m</td></tr> </table>	1.40	0.606kg/m	2.00	0.766kg/m		<p><b>50JF102</b></p> <p>竖外框</p> <table border="1"> <tr><td>1.40</td><td>0.532kg/m</td></tr> <tr><td>2.00</td><td>0.679kg/m</td></tr> </table>	1.40	0.532kg/m	2.00	0.679kg/m		<p><b>50JF103</b></p> <p>孔中挺</p> <table border="1"> <tr><td>1.40</td><td>0.955kg/m</td></tr> <tr><td>2.00</td><td>1.222kg/m</td></tr> </table>	1.40	0.955kg/m	2.00	1.222kg/m	
1.40	0.606kg/m																
2.00	0.766kg/m																
1.40	0.532kg/m																
2.00	0.679kg/m																
1.40	0.955kg/m																
2.00	1.222kg/m																
<p><b>50JF104</b></p> <p>中挺</p> <table border="1"> <tr><td>1.40</td><td>0.880kg/m</td></tr> <tr><td>2.00</td><td>1.134kg/m</td></tr> </table>	1.40	0.880kg/m	2.00	1.134kg/m		<p><b>50JF105</b></p> <p>滴水中挺</p> <table border="1"> <tr><td>1.40</td><td>1.006kg/m</td></tr> </table>	1.40	1.006kg/m		<p><b>50JF106</b></p> <p>加强中挺</p> <table border="1"> <tr><td>1.40</td><td>1.268kg/m</td></tr> </table>	1.40	1.268kg/m					
1.40	0.880kg/m																
2.00	1.134kg/m																
1.40	1.006kg/m																
1.40	1.268kg/m																
<p><b>50JF201</b></p> <p>窗扇</p> <table border="1"> <tr><td>1.40</td><td>0.781kg/m</td></tr> </table> <p>角码HL50014</p>	1.40	0.781kg/m		<p><b>50JF202</b></p> <p>门扇</p> <table border="1"> <tr><td>2.00</td><td>1.344kg/m</td></tr> </table> <p>角码HL50014</p>	2.00	1.344kg/m		<p><b>50JF203</b></p> <p>对开扇边</p> <table border="1"> <tr><td>1.40</td><td>0.967kg/m</td></tr> <tr><td>2.00</td><td>1.272kg/m</td></tr> </table> <p>角码HL50014</p>	1.40	0.967kg/m	2.00	1.272kg/m					
1.40	0.781kg/m																
2.00	1.344kg/m																
1.40	0.967kg/m																
2.00	1.272kg/m																
<p><b>50JF204</b></p> <p>门中横</p> <table border="1"> <tr><td>2.00</td><td>1.840kg/m</td></tr> </table>	2.00	1.840kg/m															
2.00	1.840kg/m																
<p><b>50JF301</b></p> <p>单玻压线</p> <table border="1"> <tr><td>1.00</td><td>0.212kg/m</td></tr> </table> <p>槽口 12.5</p>	1.00	0.212kg/m		<p><b>50JF302</b></p> <p>中空压线</p> <table border="1"> <tr><td>1.00</td><td>0.189kg/m</td></tr> </table> <p>槽口 24.5</p>	1.00	0.189kg/m		<p><b>50JF303</b></p> <p>中空压线</p> <table border="1"> <tr><td>1.00</td><td>0.189kg/m</td></tr> </table> <p>槽口 28</p>	1.00	0.189kg/m							
1.00	0.212kg/m																
1.00	0.189kg/m																
1.00	0.189kg/m																
<p><b>50JF304</b></p> <p>连接件</p> <table border="1"> <tr><td>1.40</td><td>0.545kg/m</td></tr> </table>	1.40	0.545kg/m		<p><b>HL50014</b></p> <p>空心角码</p> <table border="1"> <tr><td>2.20</td><td>1.278kg/m</td></tr> </table>	2.20	1.278kg/m		<p><b>HL50019</b></p> <p>角码</p> <table border="1"> <tr><td>2.410kg/m</td><td></td></tr> </table>	2.410kg/m								
1.40	0.545kg/m																
2.20	1.278kg/m																
2.410kg/m																	

# 55JK系列隔热平开窗结构图一(内开内倒)

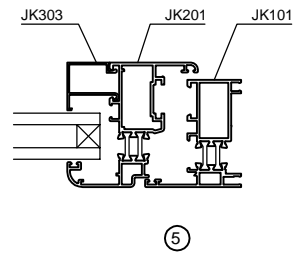
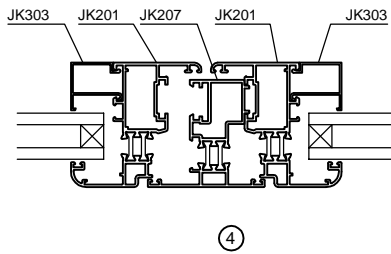
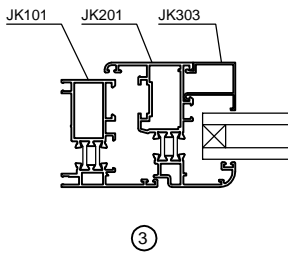
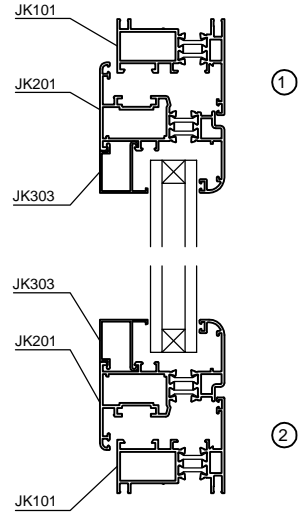
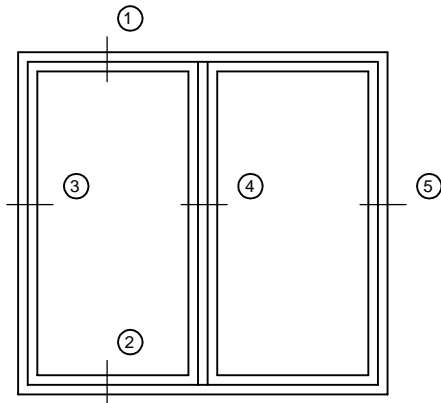

# 55JK系列隔热平开窗结构图二(外开合页)

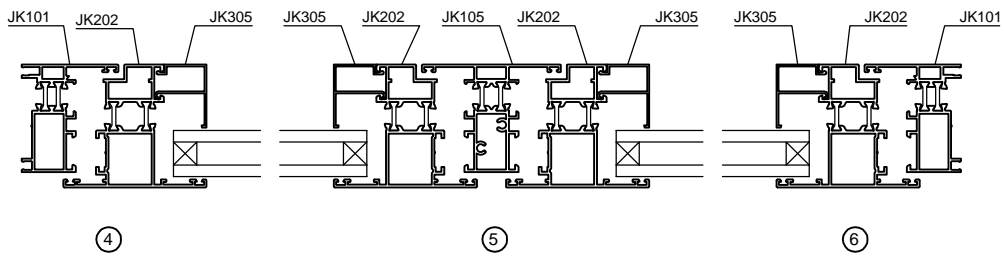
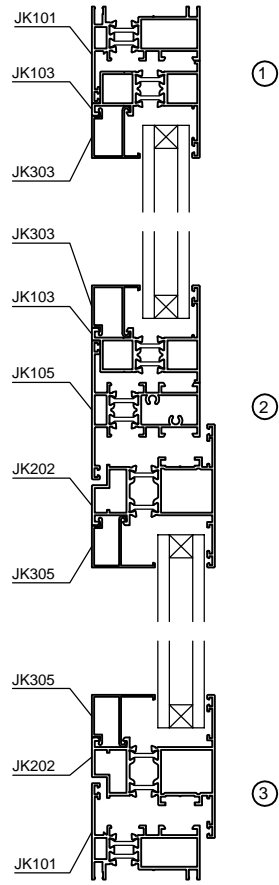
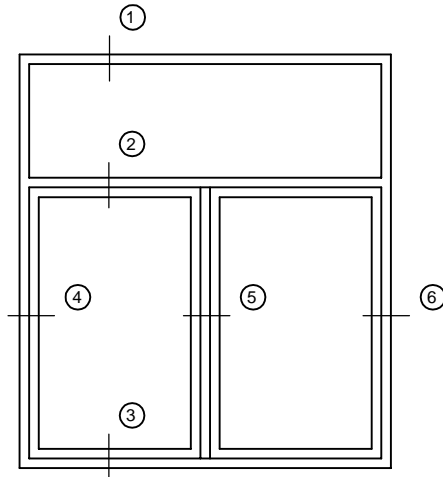





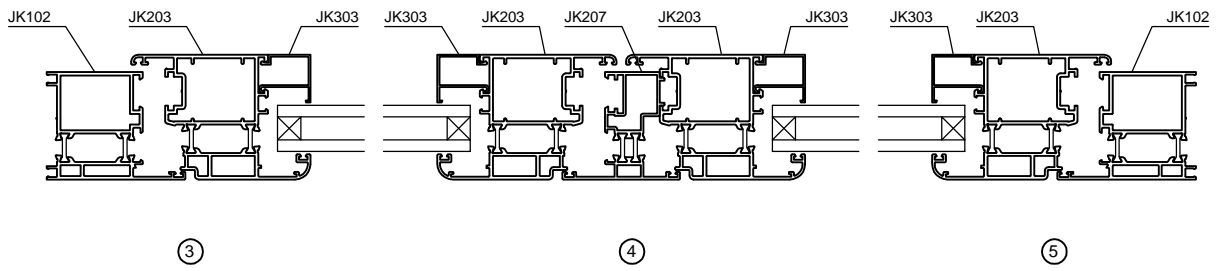
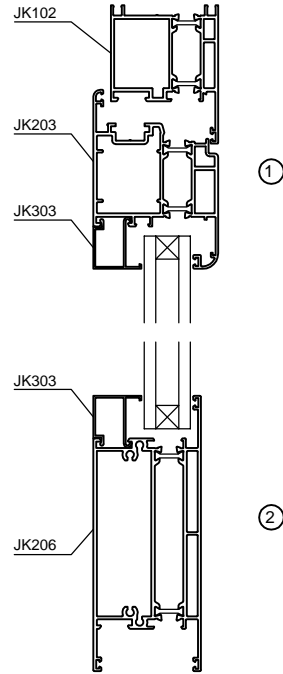
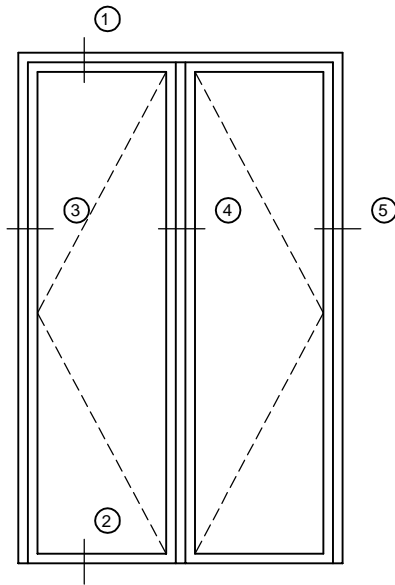

# 55JK系列隔热平开门结构图一(内对开)

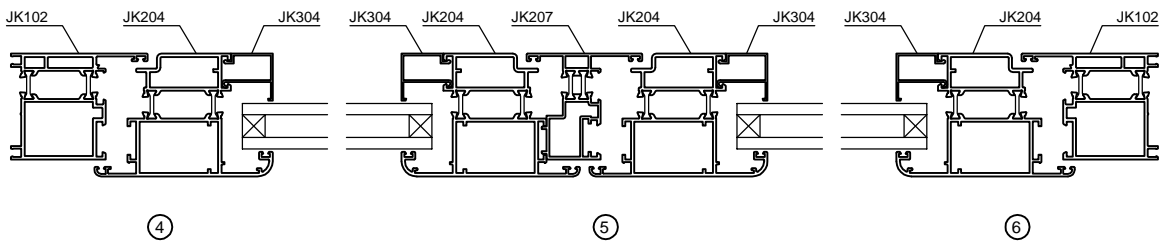
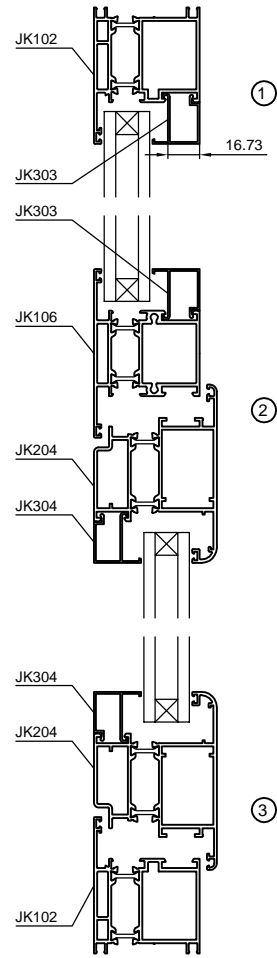
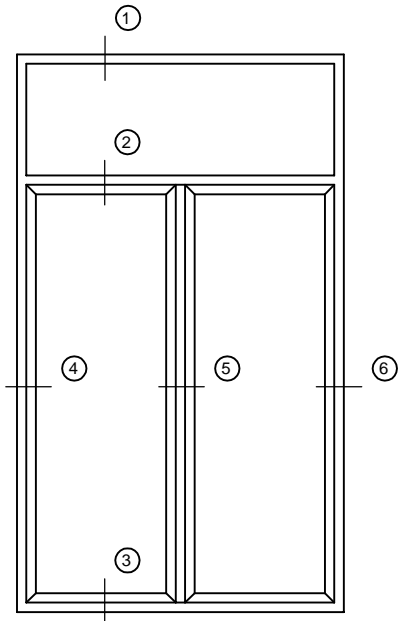

# 55JK系列隔热平开门结构图二(外对开)

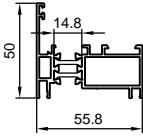
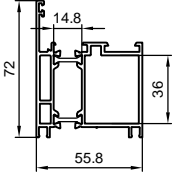
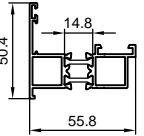
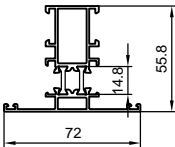
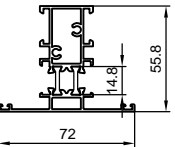
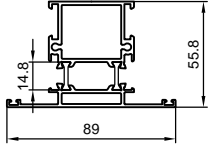
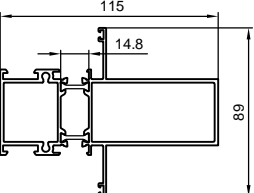
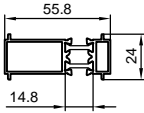
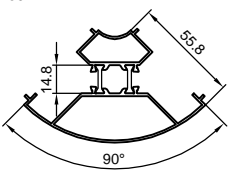
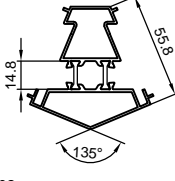
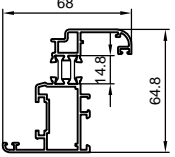
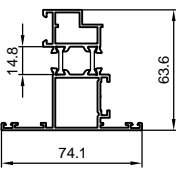
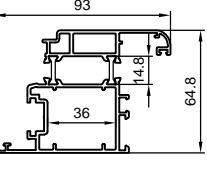
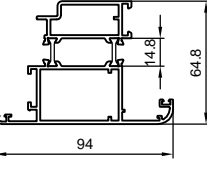
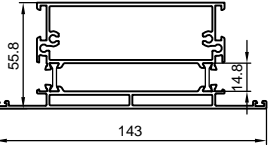
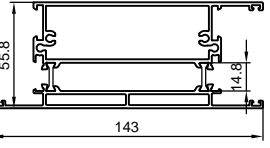
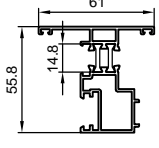

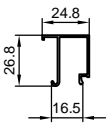
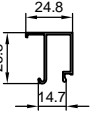
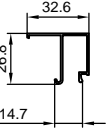
# 55JK系列隔热平开门、窗型材图一

<p><b>JK101</b></p> <p>窗框</p> <p>1.40 1.087kg/m</p> <p>角码JX101 压线JK301、JK303</p>	<p>JK1011</p> 	<p>JK1012</p>	<p><b>JK102</b></p> <p>门框</p> <p>1.80 1.659kg/m</p> <p>角码JX102 压线JK301、JK303</p>	<p>JK1021</p> 	<p>JK1022</p>	<p><b>JK103</b></p> <p>转换框</p> <p>1.40 0.955kg/m</p> <p>角码JX101 压线JK301、JK303</p>	<p>JK1031</p> 	<p>JK1032</p>
<p><b>JK104</b></p> <p>中挺</p> <p>1.40 1.248kg/m</p> <p>压线JK301、JK303</p>	<p>JK1041</p> 	<p>JK1042</p>	<p><b>JK105</b></p> <p>中挺</p> <p>1.40 1.329kg/m</p> <p>压线JK301、JK303</p>	<p>JK1051</p> 	<p>JK1052</p>	<p><b>JK106</b></p> <p>门中挺</p> <p>1.80 1.744kg/m</p> <p>压线JK301、JK303</p>	<p>JK1061</p> 	<p>JK1062</p>
<p><b>JK107</b></p> <p>加强门中挺</p> <p>1.80 2.323kg/m</p> <p>压线JK301、JK303</p>	<p>JK1061</p> 	<p>JK1071</p>	<p><b>JK108</b></p> <p>连接料</p> <p>1.20 0.784kg/m</p>	<p>JK1081</p> 	<p>JK1082</p>	<p><b>JK109</b></p> <p>转角</p> <p>1.20 1.293kg/m</p>	<p>JK1091</p> 	<p>JK1092</p>
<p><b>JK110</b></p> <p>转角</p> <p>1.20 1.224kg/m</p>	<p>JK1101</p> 	<p>JK1102</p>	<p><b>JK201</b></p> <p>内开窗扇</p> <p>1.40 1.287kg/m</p> <p>角码JX101 压线JK301、JK303</p>	<p>JK2011</p> 	<p>JK2012</p>	<p><b>JK202</b></p> <p>外开窗扇</p> <p>1.40 1.357kg/m</p> <p>角码JX103 压线JK305</p>	<p>JK2021</p> 	<p>JK2022</p>
<p><b>JK203</b></p> <p>内开门扇</p> <p>1.80 1.999kg/m</p> <p>角码JX102 压线JK301、JK303</p>	<p>JK2031</p> 	<p>JK2032</p>	<p><b>JK204</b></p> <p>外开门扇</p> <p>1.80 1.945kg/m</p> <p>角码JX102 压线JK304</p>	<p>JK2041</p> 	<p>JK2042</p>	<p><b>JK205</b></p> <p>门中横</p> <p>1.80 2.873kg/m</p> <p>压线JK301、JK303</p>	<p>JK2051</p> 	<p>JK2052</p>
<p><b>JK206</b></p> <p>门下方</p> <p>1.80 3.000kg/m</p> <p>压线JK301、JK303</p>	<p>JK2061</p> 	<p>JK2062</p>	<p><b>JK207</b></p> <p>假中挺</p> <p>1.40 1.164kg/m</p>	<p>JK2071</p> 	<p>JK2072</p>	<p><b>JK301</b></p> <p>圆压线</p> <p>1.00 0.220kg/m</p> <p>槽口27</p>	<p>JK301</p> 	
<p><b>JK302</b></p> <p>假压线</p> <p>1.00 0.174kg/m</p> <p>槽口27</p>	<p>JK302</p> 	<p>JK302</p>	<p><b>JK303</b></p> <p>压线</p> <p>1.00 0.233kg/m</p> <p>槽口27</p>	<p>JK303</p> 	<p>JK303</p>	<p><b>JK304</b></p> <p>压线</p> <p>1.00 0.233kg/m</p> <p>槽口27</p>	<p>JK304</p> 	
<p><b>JK305</b></p> <p>压线</p> <p>1.00 0.255kg/m</p> <p>槽口27</p>	<p>JK305</p> 	<p>JK305</p>	<p><b>JK306</b></p> <p>框拼接</p> <p>1.20 0.097kg/m</p>	<p>JK306</p> 	<p>JK306</p>			

# 65JL系列隔热平开窗结构图(内开)

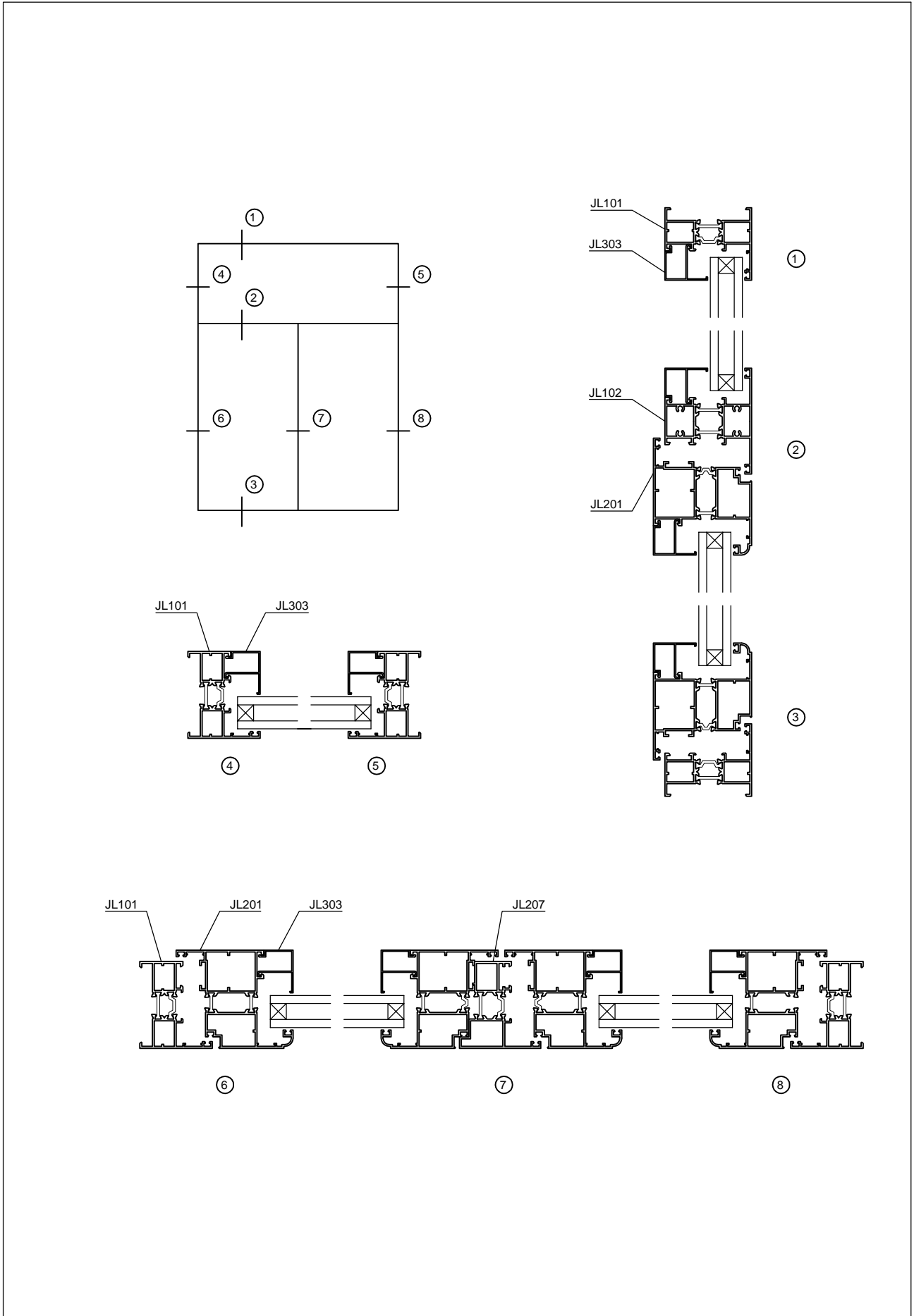

# 65JL系列隔热平开窗结构图(外开)

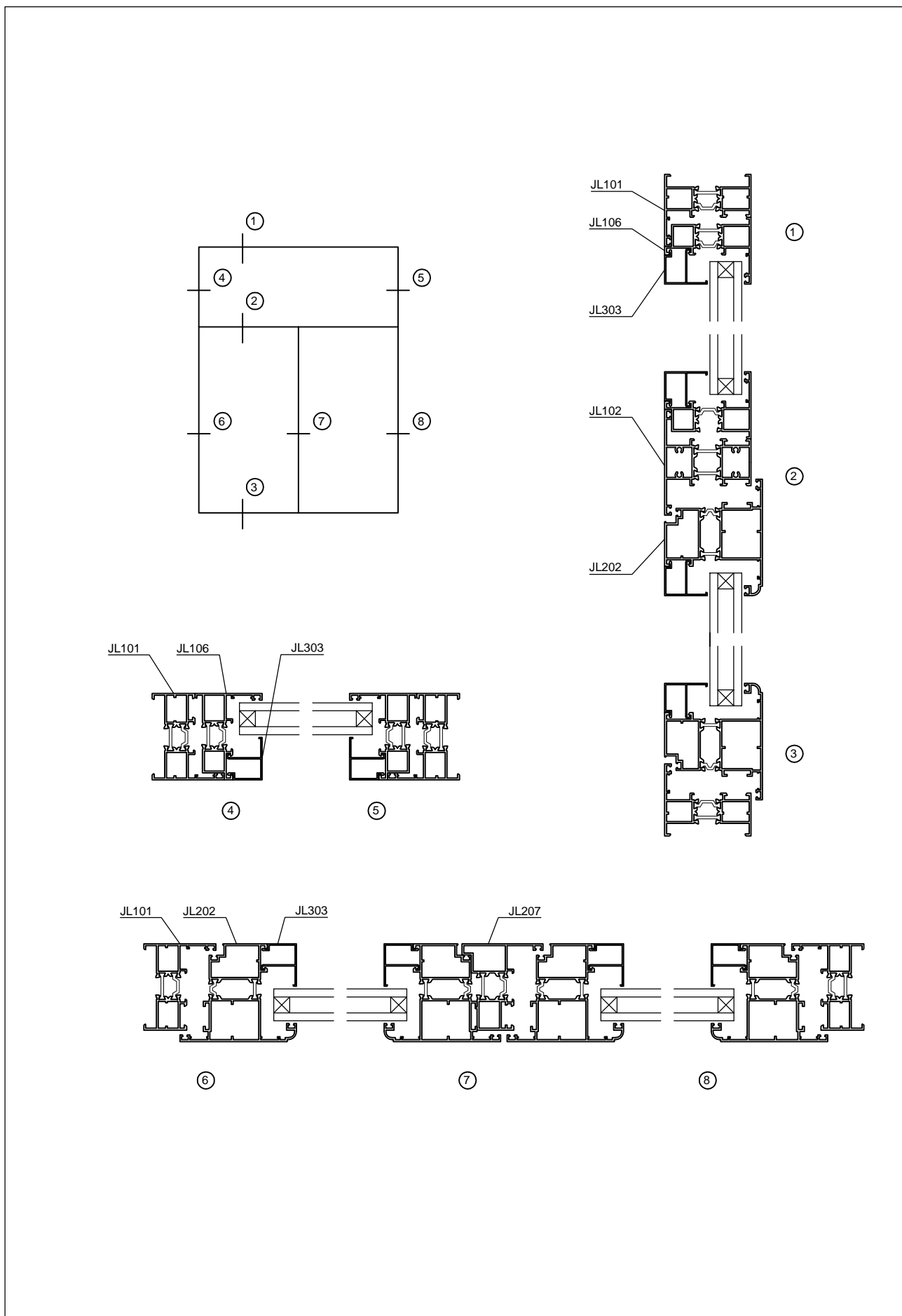

# 65JL系列隔热平开门、窗型材图一

<p><b>JL101</b></p> <p>窗框</p> <p>1.40 1.175kg/m</p> <p>活动角码或JX101</p>	<p>JL1011 JL1012</p>	<p><b>JL102</b></p> <p>中挺</p> <p>1.40 1.512kg/m</p>	<p>JL1021</p>	<p><b>JL103</b></p> <p>门框</p> <p>1.80 1.771kg/m</p> <p>角码JX102</p>	<p>JL1031 JL1032</p>
<p><b>JL104</b></p> <p>门中挺</p> <p>1.80 2.013kg/m</p>	<p>JL1041</p>	<p><b>JL105</b></p> <p>加强中挺</p> <p>1.40 2.040kg/m</p>	<p>JL1051 JL1021</p>	<p><b>JL106</b></p> <p>转换框</p> <p>1.40 1.075kg/m</p> <p>角码JX101</p>	<p>JL1061 JL1062</p>
<p><b>JL107</b></p> <p>90°转角</p> <p>1.20 1.622kg/m</p>	<p>JL1071</p>	<p><b>JL108</b></p> <p>135°转角</p> <p>1.20 1.056kg/m</p>	<p>JL1081</p>	<p><b>JL109</b></p> <p>拼接件</p> <p>1.20 0.798kg/m</p>	<p>JL1091 JL1091</p>
<p><b>JL201</b></p> <p>内开窗扇</p> <p>1.40 1.704kg/m</p> <p>活动角码或JX102</p>	<p>JL2011 JL2012</p>	<p><b>JL202</b></p> <p>外开窗扇</p> <p>1.40 1.704kg/m</p> <p>活动角码或JX102</p>	<p>JL2021 JL2022</p>	<p><b>JL203</b></p> <p>内开门扇</p> <p>1.80 2.216kg/m</p> <p>角码JX104</p>	<p>JL2031 JL2032</p>
<p><b>JL204</b></p> <p>外开门扇</p> <p>1.80 2.214kg/m</p> <p>角码JX104</p>	<p>JL2041 JL2042</p>	<p><b>JL205</b></p> <p>门中横</p> <p>1.80 3.058kg/m</p>	<p>JL2051</p>	<p>JL2052</p>	
<p><b>JL206</b></p> <p>门下横</p> <p>1.80 3.559kg/m</p>	<p>JL2061</p>		<p><b>JL207</b></p> <p>假中挺</p> <p>1.40 1.242kg/m</p>	<p>JL2071 JL2072</p>	
<p><b>JL208</b></p> <p>小窗扇</p> <p>1.80 1.692kg/m</p>	<p>JL2081 JL2082</p>	<p><b>JL209</b></p> <p>纱扇</p> <p>1.80 1.237kg/m</p> <p>压线JM304</p>		<p><b>JL210</b></p> <p>内开窗扇</p> <p>1.40 1.722kg/m</p> <p>活动角码或JX102</p>	<p>JL2011 JL2101</p>





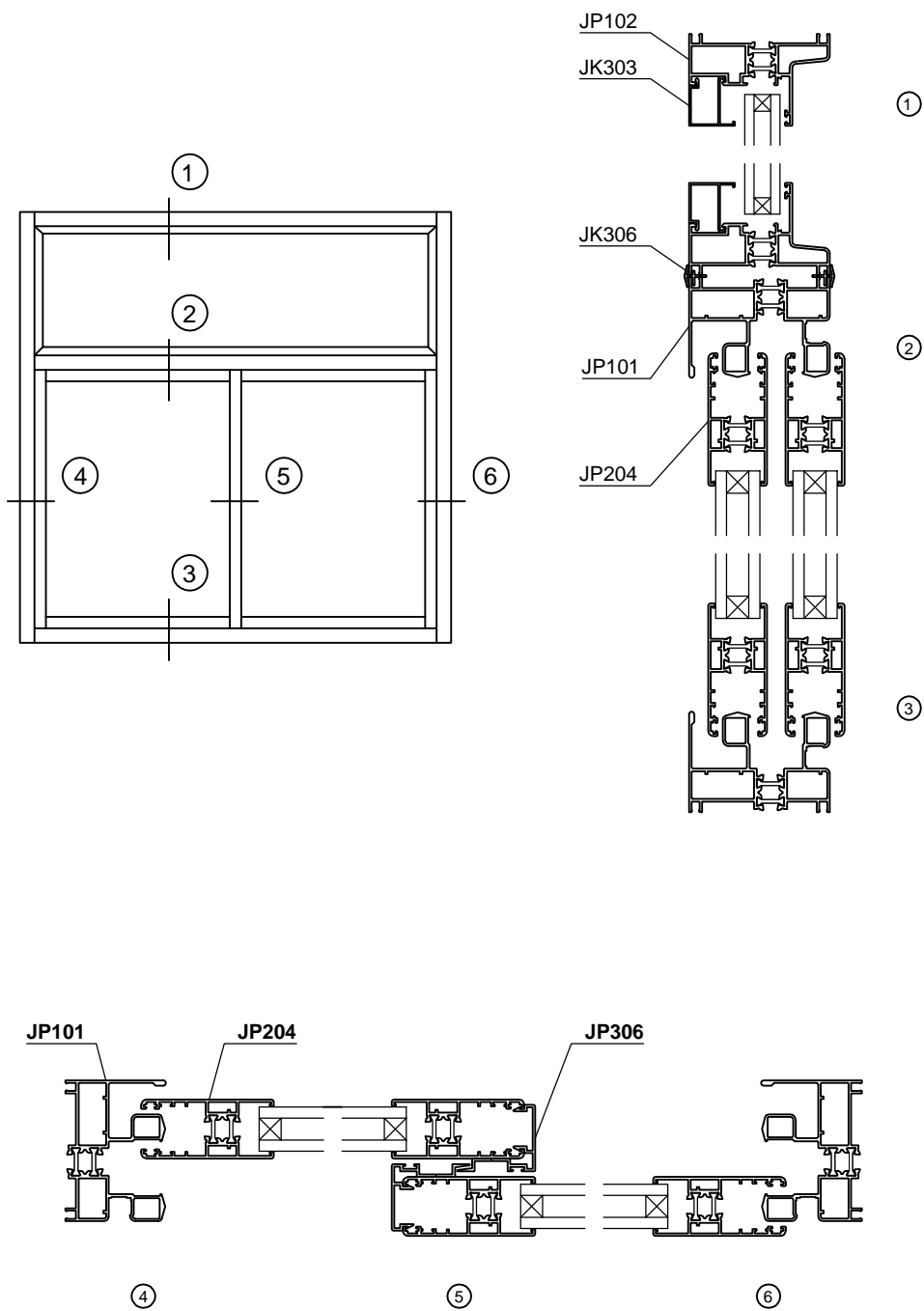



# 70JP系列隔热推拉窗结构图

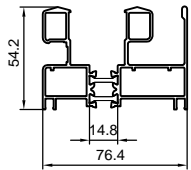
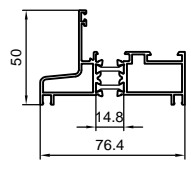
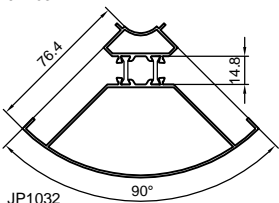
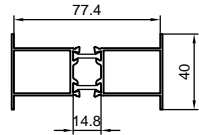
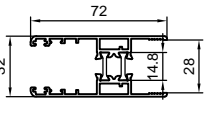
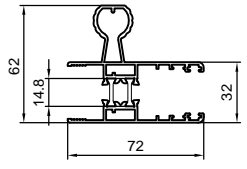
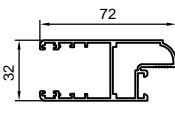
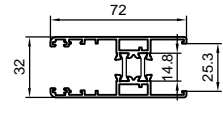
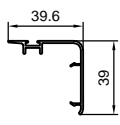

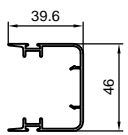
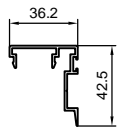
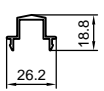
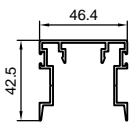
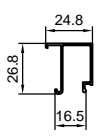
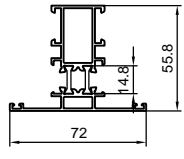
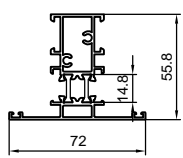

# 70JP系列隔热推拉门、窗型材图

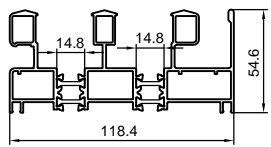
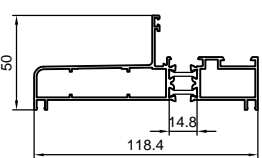
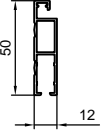
<p><b>JP101</b></p> <p>窗框</p> <p>1.40 1.791kg/m</p> <p>1.80 2.052kg/m</p> <p>活动角码</p>	<p>JP1011</p> 	<p>JP1012</p>	<p><b>JP102</b></p> <p>固定框</p> <p>1.40 1.250kg/m</p> <p>活动角码</p>	<p>JP1021</p> 	<p>JP1022</p>	<p><b>JP103</b></p> <p>转角</p> <p>1.20 1.527kg/m</p> <p>活动角码</p>	<p>JP1031</p>  <p>JP1032</p>
<p><b>JP104</b></p> <p>连接件</p> <p>1.20 1.080kg/m</p>	<p>JP1041</p> 	<p>JP1041</p>	<p><b>JP201</b></p> <p>窗扇</p> <p>1.40 1.164kg/m</p> <p>1.80 1.296kg/m</p> <p>活动角码</p>	<p>JP2011</p> 	<p>JP2011</p>	<p><b>JP202</b></p> <p>拉手扇</p> <p>1.40 1.527kg/m</p> <p>1.80 1.660kg/m</p> <p>活动角码</p>	<p>JP2021</p>  <p><b>JP2011</b></p>
<p><b>JP203</b></p> <p>纱框</p> <p>1.40 0.930kg/m</p> <p>压线JP304</p>		<p><b>JP204</b></p> <p>窗扇</p> <p>1.40 1.166kg/m</p> <p>活动角码</p>	<p>JP2041</p> 	<p>JP2041</p>	<p><b>JP301</b></p> <p>挂钩</p> <p>1.20 0.317kg/m</p>		
<p><b>JP302</b></p> <p>收口</p> <p>1.20 0.211kg/m</p>		<p><b>JP303</b></p> <p>压线</p> <p>1.00 0.226kg/m</p> <p>槽口30</p>		<p>JP303</p>	<p><b>JP304</b></p> <p>纱压线</p> <p>0.80 0.129kg/m</p> <p>槽口30</p>		
<p><b>JP305</b></p> <p>双面挂钩</p> <p>1.20 0.500kg/m</p>		<p><b>JP306</b></p> <p>挂钩</p> <p>1.40 0.445kg/m</p>		<p>JP306</p>	<p><b>JP308</b></p> <p>收口</p> <p>1.20 0.219kg/m</p>		
<p><b>JP309</b></p> <p>双挂钩</p> <p>1.40 0.679kg/m</p>		<p><b>JK303</b></p> <p>压线</p> <p>1.00 0.233kg/m</p> <p>槽口27.2</p>		<p>JK303</p>	<p><b>JK104</b></p> <p>中挺</p> <p>1.40 1.248kg/m</p> <p>压线JK301、JK303</p>	<p>JK1041</p>  <p>JK1042</p>	
<p><b>JK105</b></p> <p>中挺</p> <p>1.40 1.329kg/m</p> <p>压线JK301、JK303</p>	<p>JK1051</p> 	<p><b>JK306</b></p> <p>框拼接</p> <p>1.20 0.097kg/m</p>		<p>JK306</p>	<p><b>HL70C510</b></p> <p>三轨框</p> <p>1.50 2.754kg/m</p>	<p>HL70C011</p> <p>HL70C511</p> <p>HL70C012</p> 	
<p><b>HL70C610</b></p> <p>宽固定框</p> <p>1.40 1.604kg/m</p>	<p>HL70C611</p> 	<p><b>JX302</b></p> <p>纱夹</p> <p>1.20 0.411kg/m</p>		<p>JX302</p>			

# 75JD系列折叠门、窗结构图

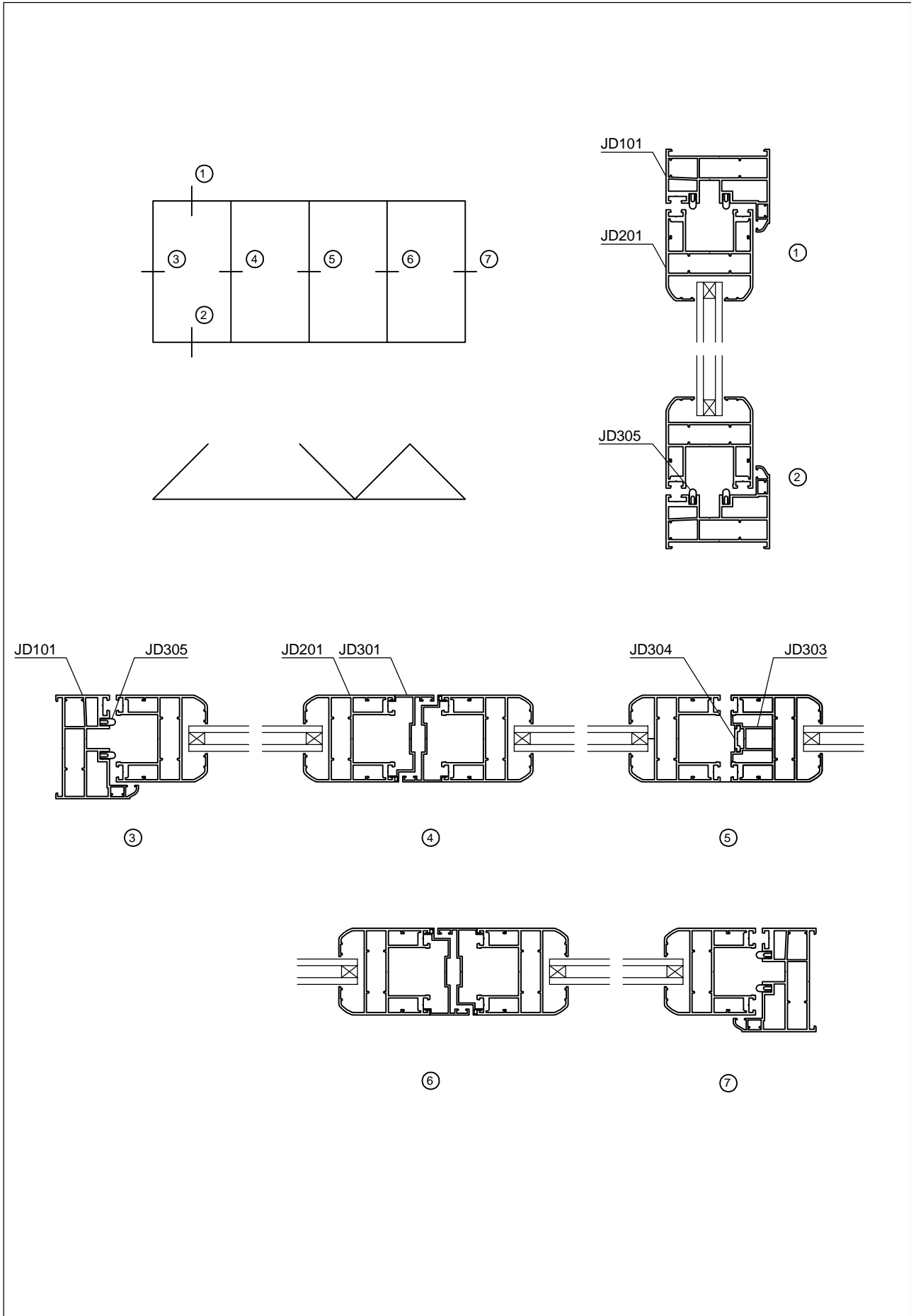



# 80AC系列隔热推拉窗结构图

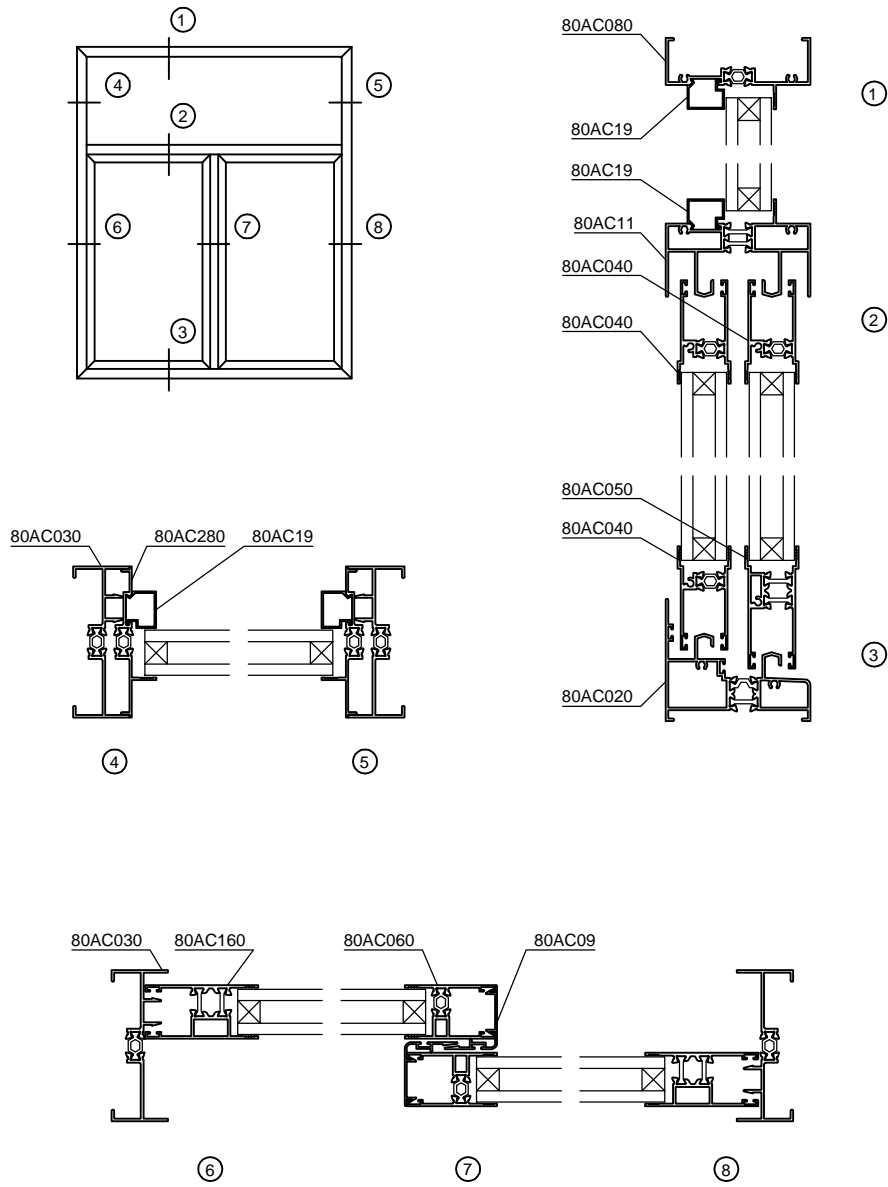

# 80AC系列隔热推拉窗型材图一

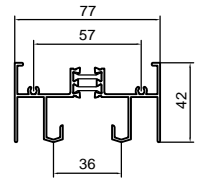
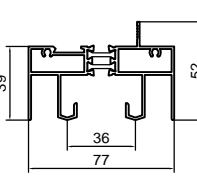
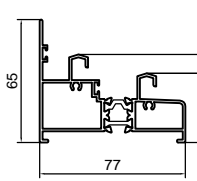
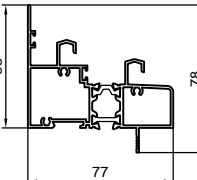
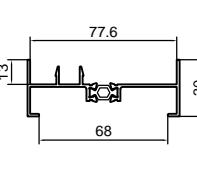
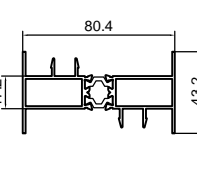
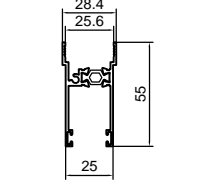
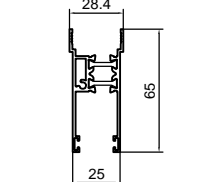
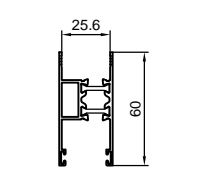
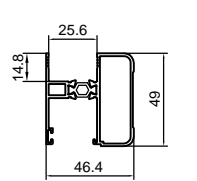
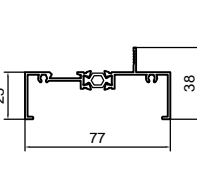
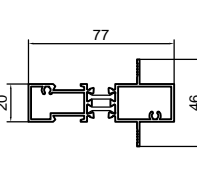
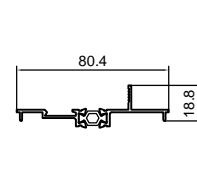
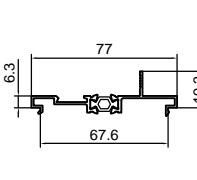
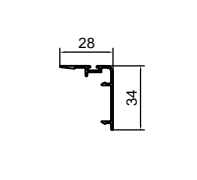
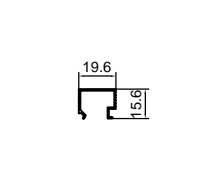
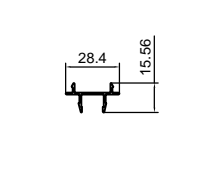
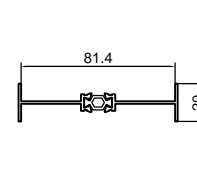
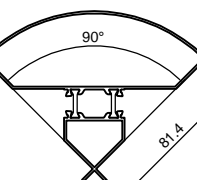
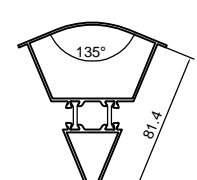
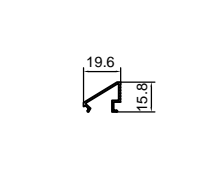
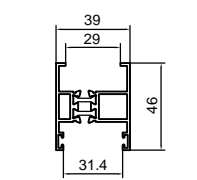
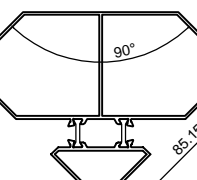
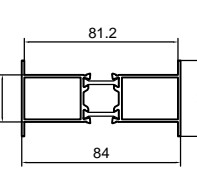
<p><b>80AC010</b></p> <p>用途 上滑</p> <p>厚度 1.40</p> <p>线密度 1.242kg/m</p>		<p><b>80AC110</b></p> <p>用途 同上滑</p> <p>厚度 1.40</p> <p>线密度 1.467kg/m</p>		<p><b>80AC020</b></p> <p>用途 下滑</p> <p>厚度 1.40</p> <p>线密度 1.503kg/m</p>	
<p><b>80AC220</b></p> <p>用途 因下滑</p> <p>厚度 1.40</p> <p>线密度 1.636kg/m</p>		<p><b>80AC030</b></p> <p>用途 边企</p> <p>厚度 1.40</p> <p>线密度 0.792kg/m</p>		<p><b>80AC130</b></p> <p>用途 双边企</p> <p>厚度 1.40</p> <p>线密度 1.322kg/m</p>	
<p><b>80AC040</b></p> <p>用途 上方</p> <p>厚度 1.40</p> <p>线密度 0.696kg/m</p>		<p><b>80AC050</b></p> <p>用途 外下方</p> <p>厚度 1.40</p> <p>线密度 0.933kg/m</p>		<p><b>80AC160</b></p> <p>用途 光企</p> <p>厚度 1.40</p> <p>线密度 0.859kg/m</p>	<p><b>80AC161</b>      <b>80AC162</b></p> 
<p><b>80AC070</b></p> <p>用途 大勾企</p> <p>厚度 1.40</p> <p>线密度 0.943kg/m</p>	<p><b>80AC061</b>      <b>80AC071</b></p> 	<p><b>80AC080</b></p> <p>用途 上固</p> <p>厚度 1.40</p> <p>线密度 0.774kg/m</p>		<p><b>80AC180</b></p> <p>用途 中固</p> <p>厚度 1.40</p> <p>线密度 1.148kg/m</p>	
<p><b>80AC280</b></p> <p>用途 边固</p> <p>厚度 1.20</p> <p>线密度 0.532kg/m</p>		<p><b>80AC380</b></p> <p>用途 反插板</p> <p>厚度 1.20</p> <p>线密度 0.582kg/m</p>		<p><b>80AC09</b></p> <p>用途 挂钩</p> <p>厚度 1.00</p> <p>线密度 0.222kg/m</p>	
<p><b>80AC19</b></p> <p>用途 方压线</p> <p>厚度 0.80</p> <p>线密度 0.124kg/m</p> <p>槽口 26.2</p>		<p><b>80AC29</b></p> <p>用途 收口</p> <p>厚度 1.00</p> <p>线密度 0.160kg/m</p>		<p><b>80AC100</b></p> <p>用途 工字件</p> <p>厚度 1.40</p> <p>线密度 0.624kg/m</p>	
<p><b>80AC200</b></p> <p>用途 90°转角</p> <p>厚度 1.20</p> <p>线密度 1.571kg/m</p>		<p><b>80AC300</b></p> <p>用途 135°转角</p> <p>厚度 1.20</p> <p>线密度 1.290kg/m</p>		<p><b>82827B</b></p> <p>用途 压线</p> <p>厚度 0.80</p> <p>线密度 0.108kg/m</p> <p>槽口 26.2</p>	 <p>借用</p>
<p><b>HL815090</b></p> <p>用途 收口</p> <p>厚度 1.40</p> <p>线密度 0.934kg/m</p>	 <p>借用</p>	<p><b>HL815290</b></p> <p>用途 转角</p> <p>厚度 1.40</p> <p>线密度 2.319kg/m</p>	 <p>借用</p>	<p><b>HL801390</b></p> <p>用途 连接件</p> <p>厚度 1.40</p> <p>线密度 1.222kg/m</p>	 <p>借用</p>

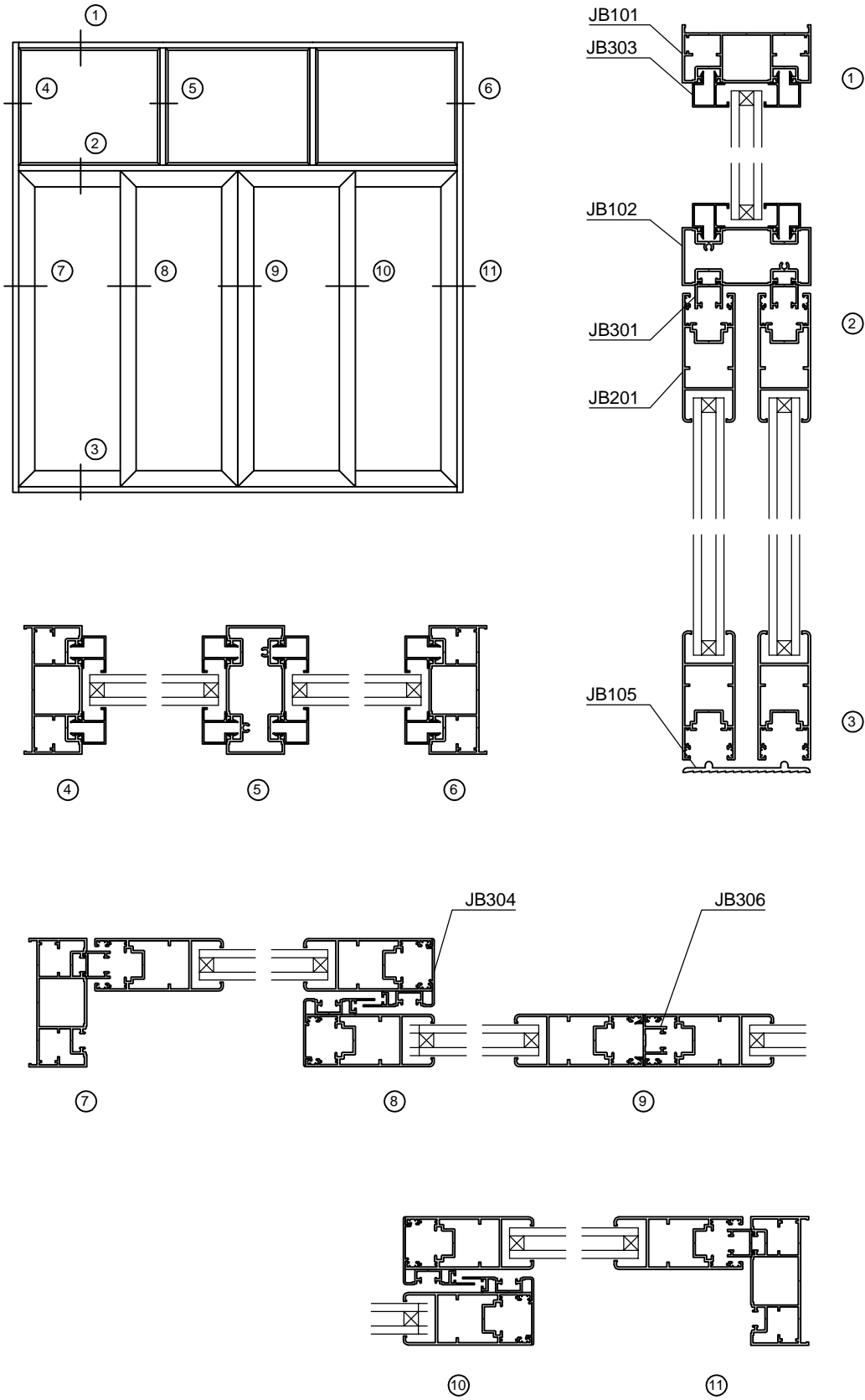

# 80JB系列推拉门结构图

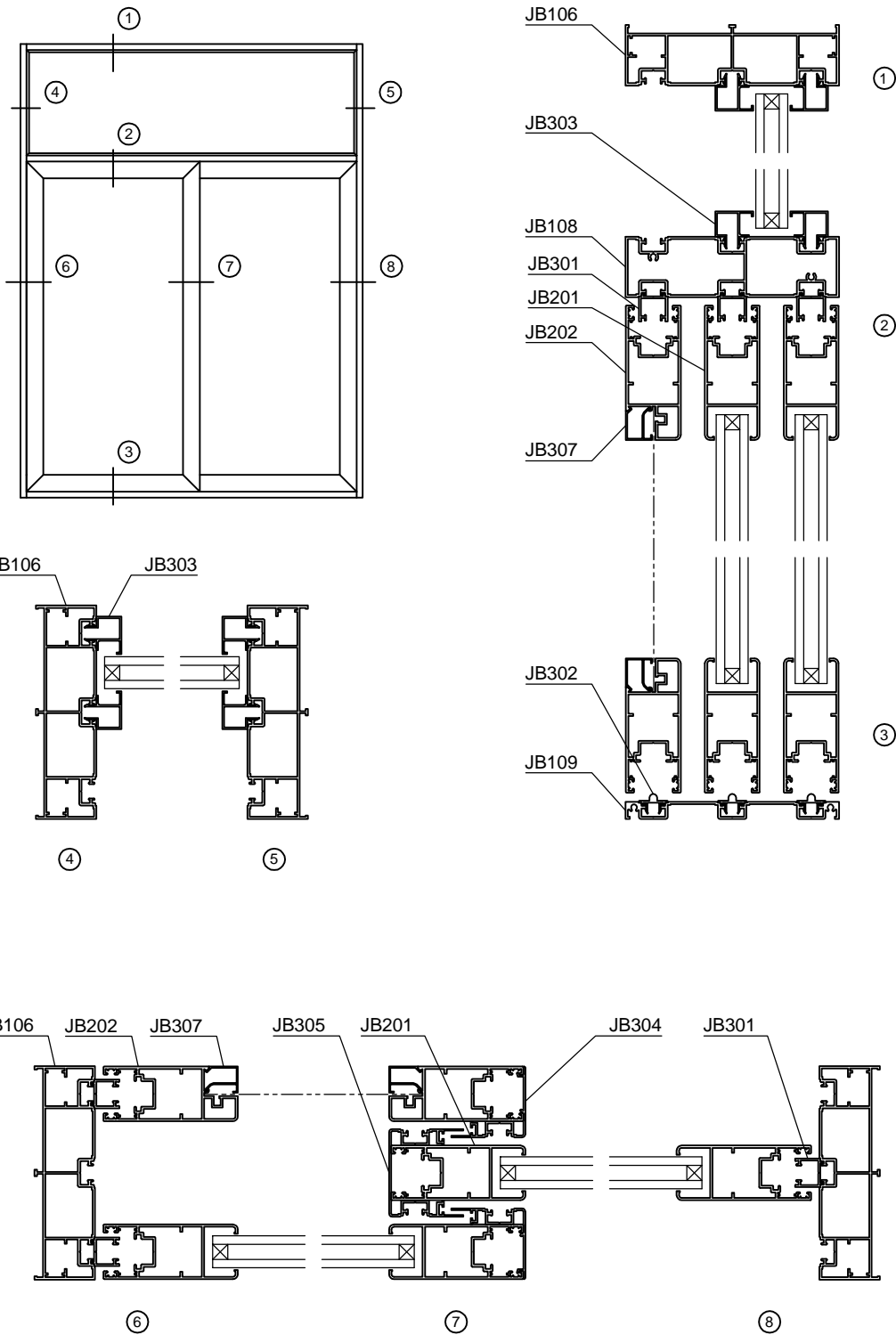

# 127JB系列推拉门结构图

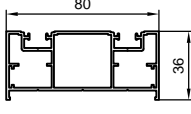
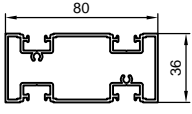
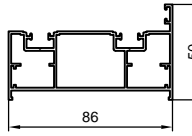
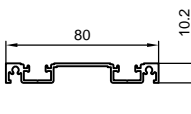
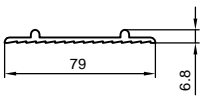
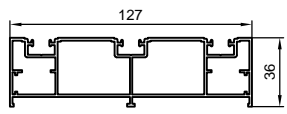
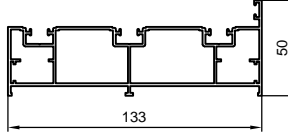
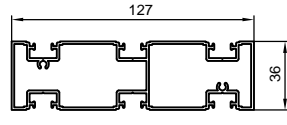
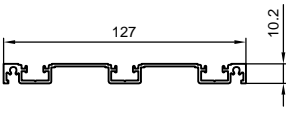
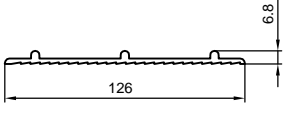
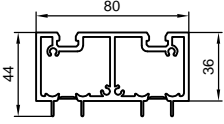
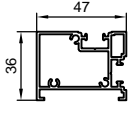
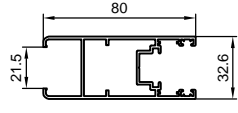
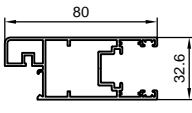
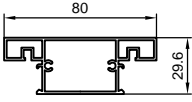
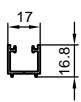
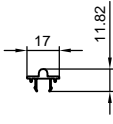
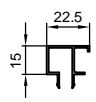
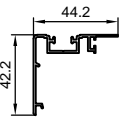
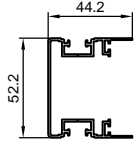
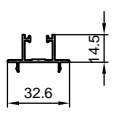

# 80/127JB系列推拉门型材图

<b>JB101</b>	壁厚	1.40	<b>JB102</b>	壁厚	1.40	<b>JB103</b>	壁厚	1.40	<b>JB104</b>	壁厚	1.40
门框	重量	1.252kg/m	框中横	重量	1.307kg/m	防水框	重量	1.377kg/m	单边框	重量	0.650kg/m
											
<b>JB105</b>	壁厚		<b>JB106</b>	壁厚	1.40	<b>JB107</b>	壁厚	1.40	<b>JB108</b>	壁厚	1.40
平轨道	重量	0.579kg/m	三轨框	重量	1.798kg/m	防水三轨框	重量	1.921kg/m	三轨框中横	重量	1.918kg/m
											
<b>JB109</b>	壁厚	1.40	<b>JB110</b>	壁厚		<b>JB111</b>	壁厚	2.50	<b>JB112</b>	壁厚	1.40
三轨单边框	重量	0.925kg/m	平轨道	重量	0.948kg/m	吊轨	重量	2.115kg/m	拼单框	重量	0.864kg/m
											
<b>JB201</b>	壁厚	1.40	<b>JB202</b>	壁厚	1.40	<b>JB203</b>	壁厚	1.40			
门扇	重量	1.056kg/m	纱门扇	重量	1.279kg/m	纱门中	重量	1.059kg/m			
											
<b>JB301</b>	壁厚	1.20	<b>JB302</b>	壁厚	1.20	<b>JB303</b>	壁厚	1.00	<b>JB304</b>	壁厚	1.20
镶条	重量	0.186kg/m	轨道	重量	0.131kg/m	框压线	重量	0.206kg/m	挂钩	重量	0.419kg/m
											
<b>JB305</b>	壁厚	1.20	<b>JB306</b>	壁厚	1.20	<b>JB307</b>	壁厚	0.80			
双挂钩	重量	0.695kg/m	收口	重量	0.255kg/m	纱压线	重量	0.128kg/m			
											



# 100JC系列门包边结构图

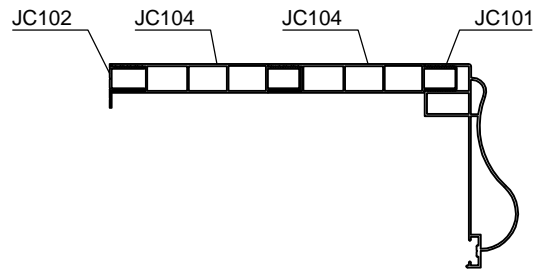



# 108JN系列隔热窗纱一体型材结构图

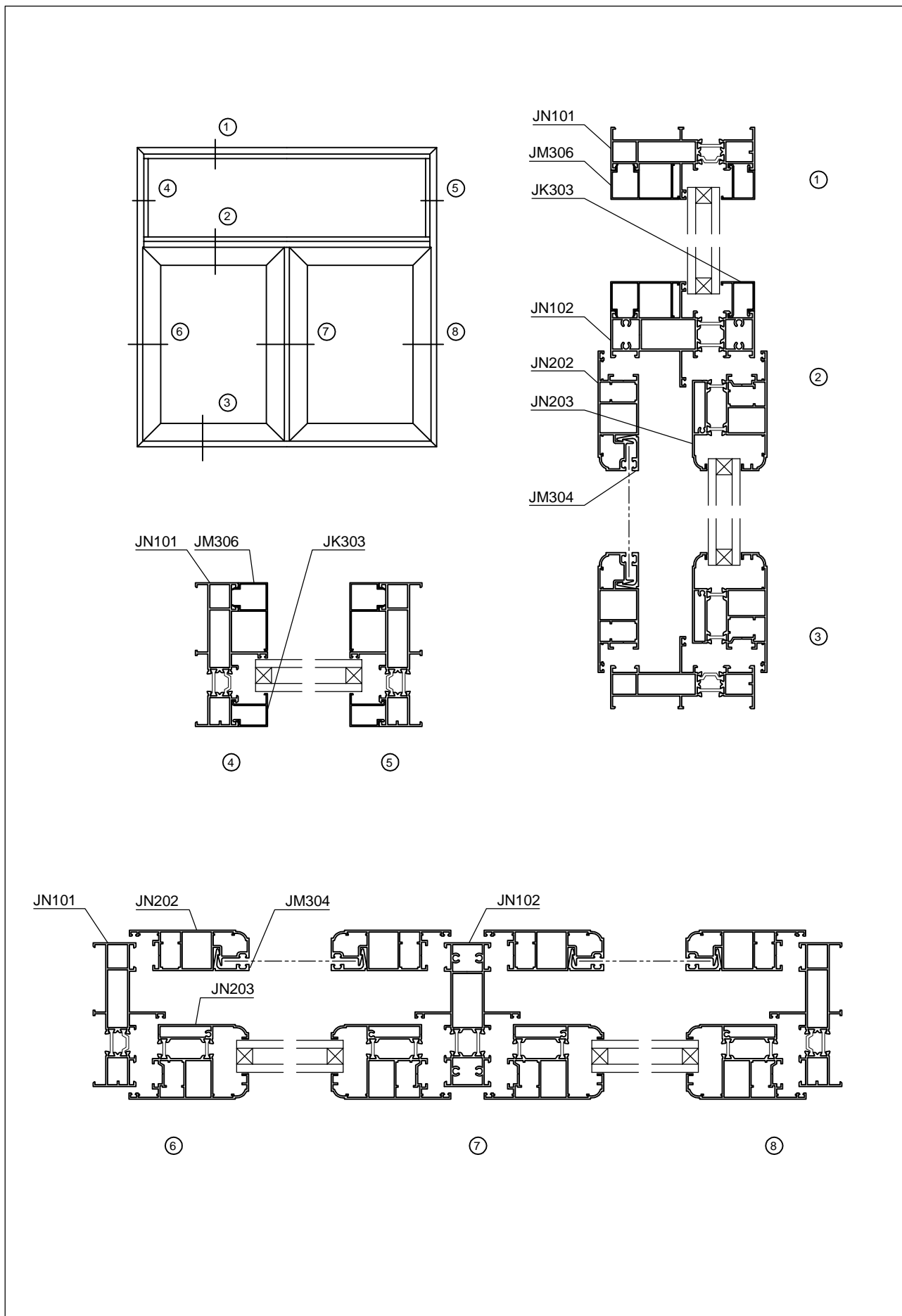

# 108JN系列隔热窗纱一体型材图

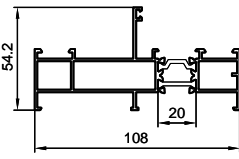
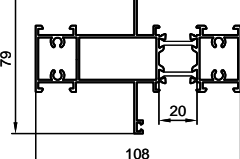
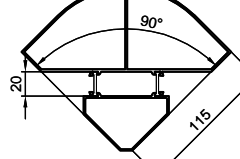
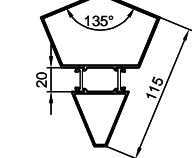
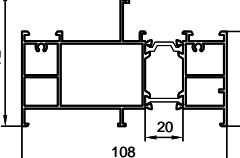
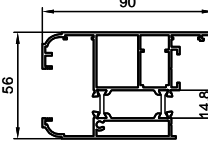
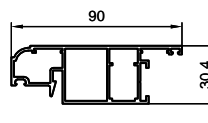
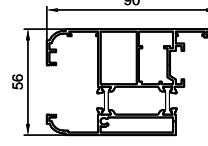
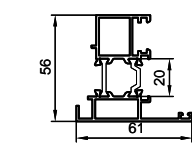
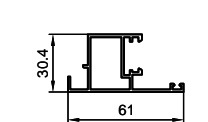
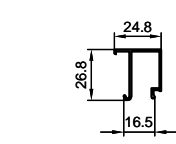
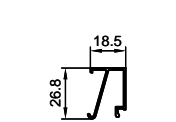
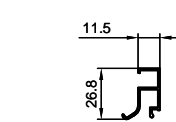
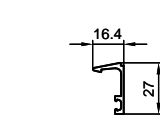
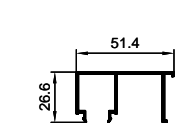
<p><b>JN101</b></p> <p>窗框</p> <p>1.40 1.633kg/m</p> <p>活动角码或JX101</p>	<p>JN1011</p> <p>JN1012</p> 	<p><b>JN102</b></p> <p>中挺</p> <p>1.40 2.059kg/m</p>	<p>JN1021</p> <p>JN1022</p> 	<p><b>JN103</b></p> <p>转角</p> <p>1.80 3.200kg/m</p>	<p>JN1031</p>  <p><b>JM1032</b></p>
<p><b>JN104</b></p> <p>转角</p> <p>1.40 2.064kg/m</p>	<p>JN1041</p>  <p><b>JM1042</b></p>	<p><b>JN105</b></p> <p>窗框</p> <p>1.40 2.152kg/m</p> <p>活动角码或JX101</p>	<p>JN1051</p> <p>JN1052</p> 		
<p><b>JN201</b></p> <p>外开窗扇</p> <p>1.40 1.779kg/m</p> <p>活动角码</p>	<p>JN2011</p>  <p>JN2012</p>	<p><b>JN202</b></p> <p>纱扇</p> <p>1.40 1.158kg/m</p> <p>活动角码或JX101</p>		<p><b>JN203</b></p> <p>窗扇</p> <p>1.40 1.791kg/m</p> <p>活动角码</p>	<p>JN2031</p>  <p>JN2032</p>
<p><b>JM204</b></p> <p>窗扇假中挺</p> <p>1.40 1.166kg/m</p>	<p>JM2041</p>  <p>JM2042</p>	<p><b>JM205</b></p> <p>纱扇假中挺</p> <p>1.40 0.680kg/m</p>			
<p><b>JK303</b></p> <p>压线</p> <p>1.00 0.233kg/m</p> <p>槽口26.7</p> <p>反面扣压, 槽口17.2</p>		<p><b>JM301</b></p> <p>压线</p> <p>1.00 0.219kg/m</p> <p>槽口33</p>		<p><b>JM302</b></p> <p>压线</p> <p>1.00 0.206kg/m</p> <p>槽口40</p>	
<p><b>JM304</b></p> <p>纱压线</p> <p>1.40 0.230kg/m</p> <p>槽口4.8</p>		<p><b>JM306</b></p> <p>压盖</p> <p>1.00 0.372kg/m</p>			

# 120JA系列重型推拉门结构图

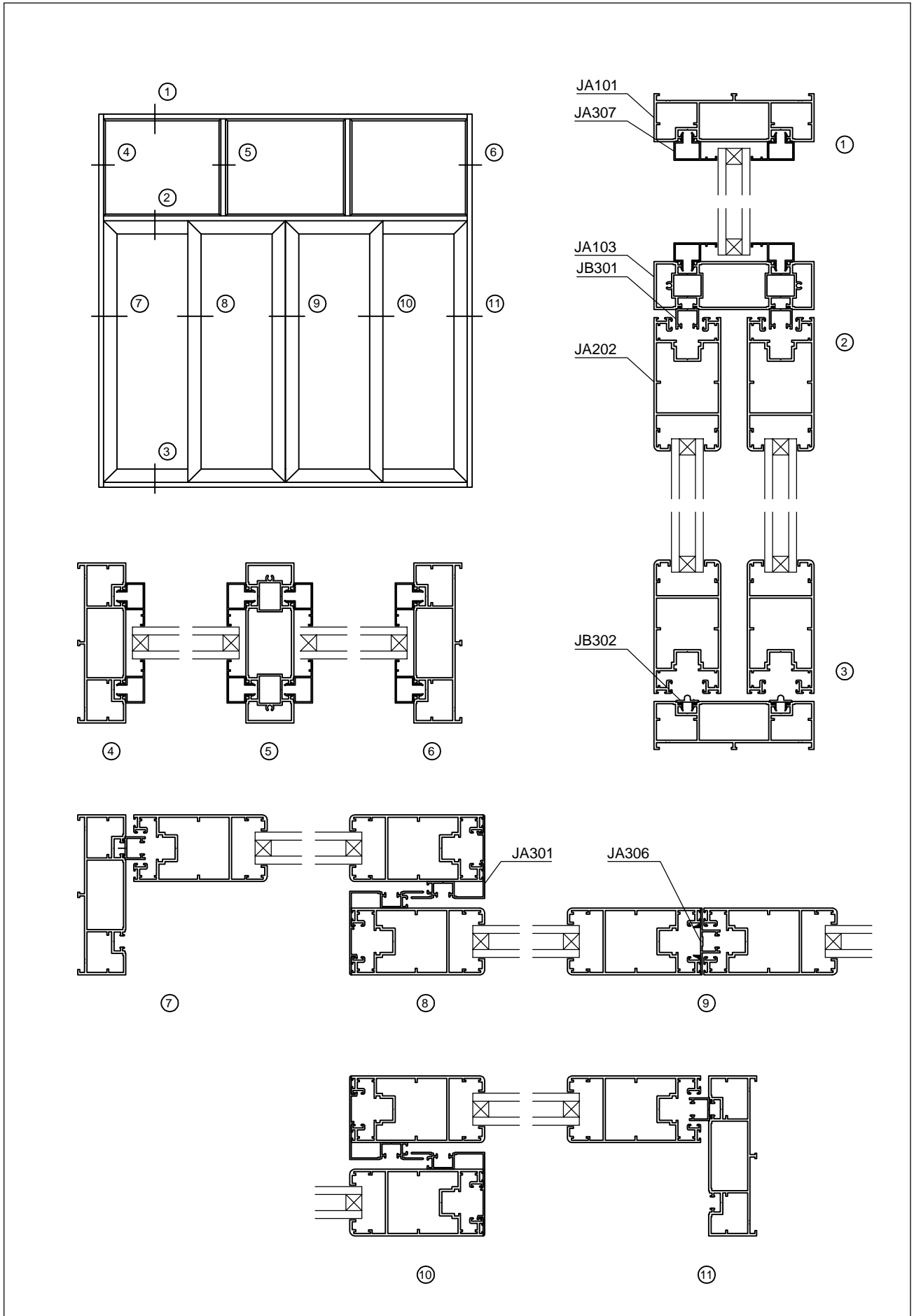



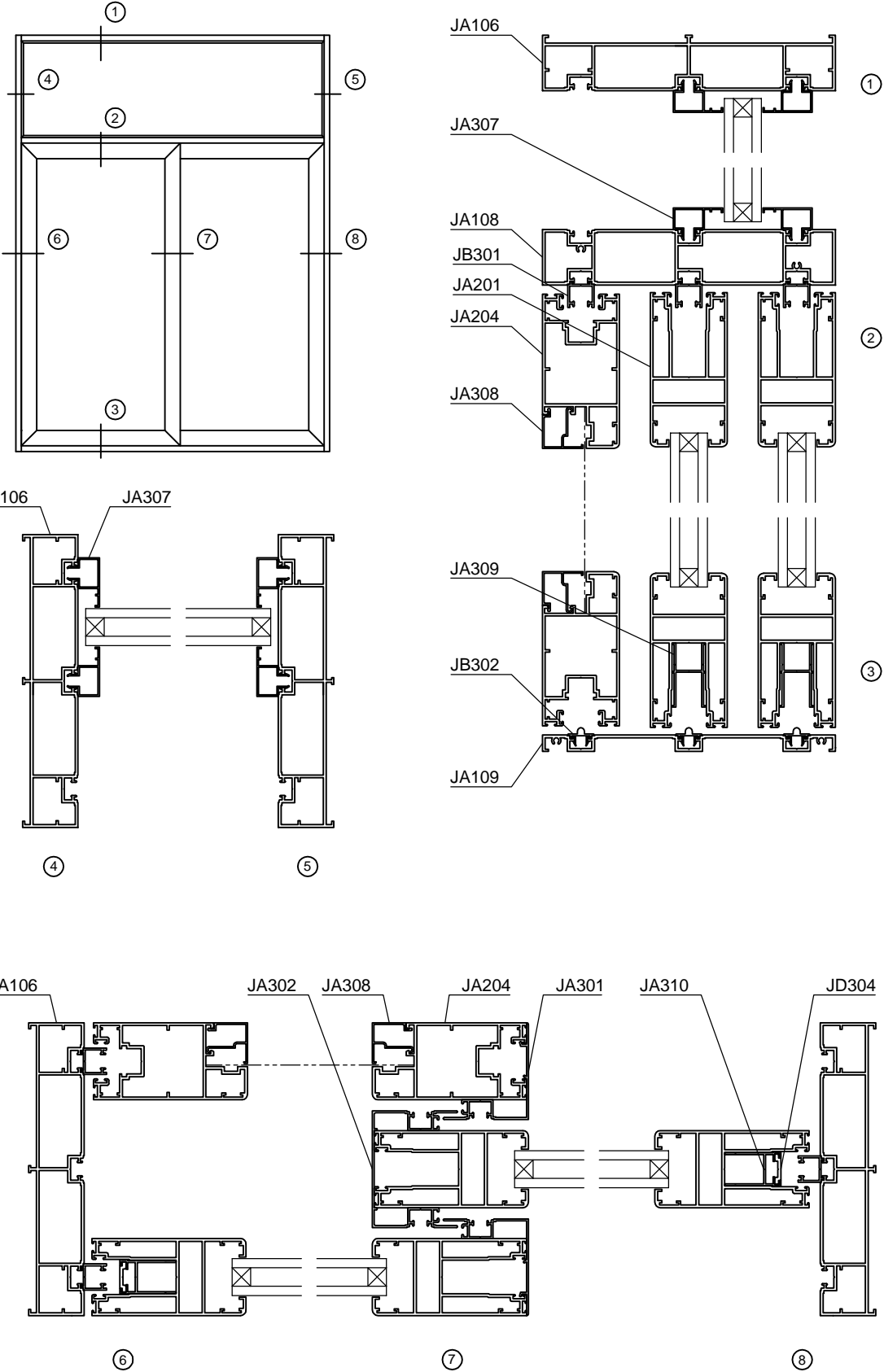

# 190JA系列重型推拉门结构图

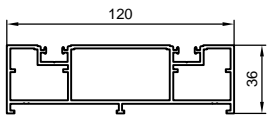
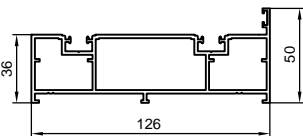
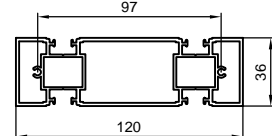
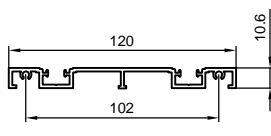
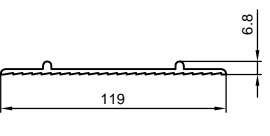
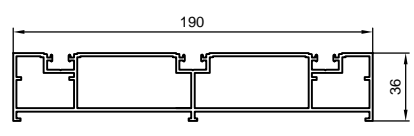
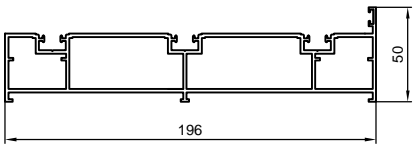
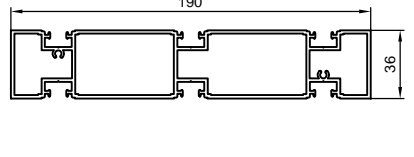
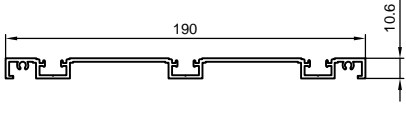
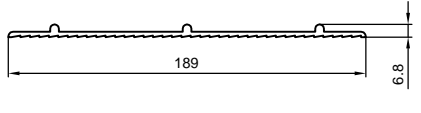
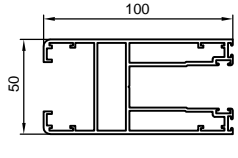
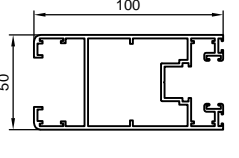
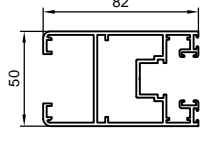
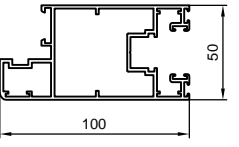
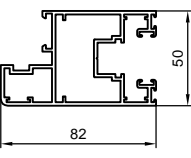
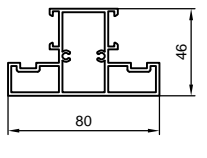
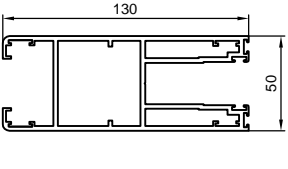
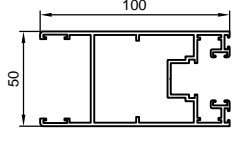

# 120/190JA系列重型推拉门型材图一

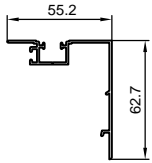
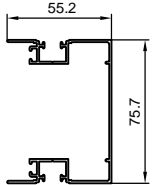
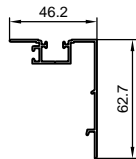
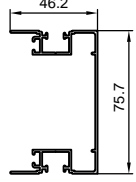
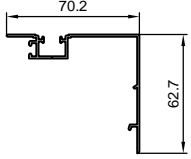
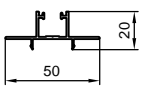
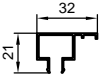
<b>JA101</b>	壁厚 1.80	<b>JA102</b>	壁厚 1.80	<b>JA103</b>	壁厚 1.80	<b>JA104</b>	壁厚 1.80
门框	重量 1.980kg/m	防水框	重量 2.121kg/m	中横	重量 2.269kg/m	底框	重量 1.034kg/m
							
<b>JA105</b>	壁厚	<b>JA106</b>	壁厚 1.80				
地平轨	重量 0.858kg/m	三轨框	重量 2.875kg/m				
							
<b>JA107</b>	壁厚 1.80			<b>JA108</b>	壁厚 1.80		
三轨防水框	重量 3.016kg/m			三轨中横	重量 3.143kg/m		
							
<b>JA109</b>	壁厚 1.80			<b>JA110</b>	壁厚		
三轨底	重量 1.441kg/m			三轨地平轨	重量 1.356kg/m		
							
<b>JA201</b>	壁厚 1.80	<b>JA202</b>	壁厚 1.80	<b>JA203</b>	壁厚 1.80	<b>JA204</b>	壁厚 1.80
扇框	重量 2.304kg/m	扇框	重量 2.008kg/m	扇框	重量 1.800kg/m	纱扇	重量 2.040kg/m
							
<b>JA205</b>	壁厚 1.80	<b>JA206</b>	壁厚 1.80	<b>JA207</b>	壁厚 2.50	<b>JA208</b>	壁厚 1.80
纱扇	重量 1.864kg/m	纱扇中横	重量 1.561kg/m	大扇框	重量 3.455kg/m	门扇	重量 1.881kg/m
							

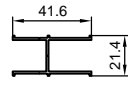
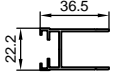
# 120/190JA系列重型推拉门型材图二

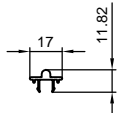
<b>JA301</b>	壁厚	1.20	<b>JA302</b>	壁厚	1.20	<b>JA303</b>	壁厚	1.20	<b>JA304</b>	壁厚	1.20
100挂钩	重量	0.542kg/m	100双挂钩	重量	0.885kg/m	82挂钩	重量	0.512kg/m	82双挂钩	重量	0.826kg/m
											
<b>JA305</b>	壁厚	1.20									
130挂钩	重量	0.591kg/m									
											
<b>JA306</b>	壁厚	1.20	<b>JA307</b>	壁厚	1.00	<b>JA308</b>	壁厚	1.00	<b>JA309</b>	壁厚	1.20
收口	重量	0.314kg/m	框压线	重量	0.230kg/m	纱压线	重量	0.245kg/m	卡槽	重量	0.343kg/m
											
<b>JA310</b>	壁厚	1.20	<b>JA311</b>	壁厚	0.60						
滑槽	重量	0.335kg/m	隔条	重量	0.105kg/m						
											
<b>JB301</b>	壁厚	1.20	<b>JB302</b>	壁厚	1.20						
镶条	重量	0.186kg/m	轨道	重量	0.131kg/m						
											



# 135JM系列隔热窗纱一体型材结构图二

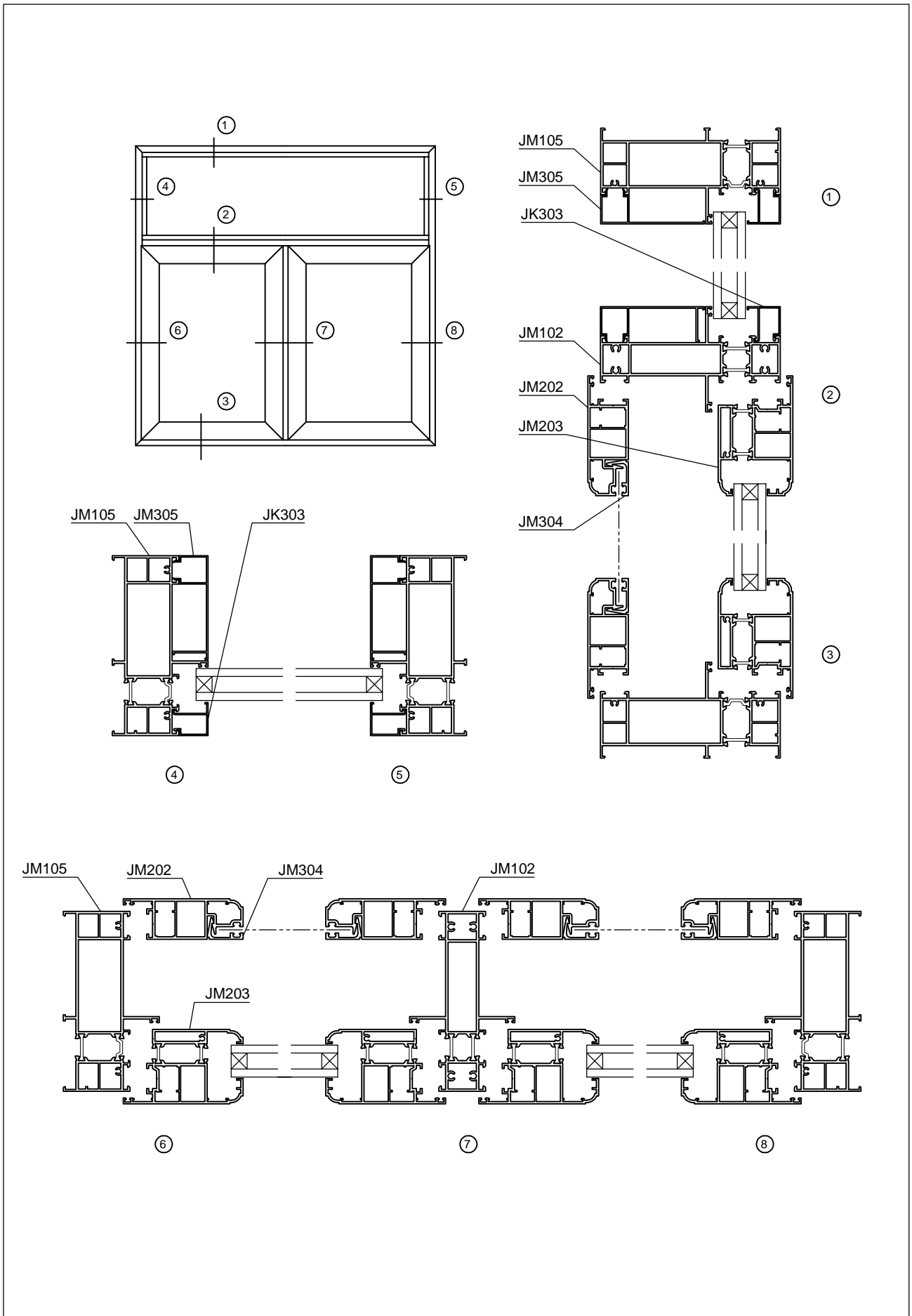

# 135JM系列隔热窗纱一体型材图

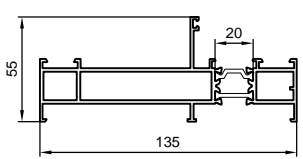
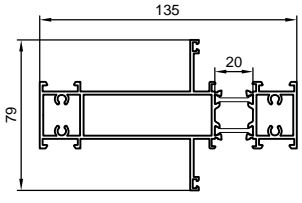
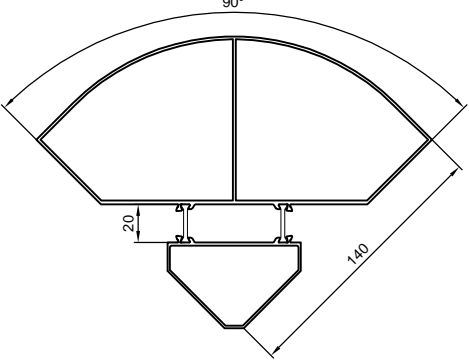
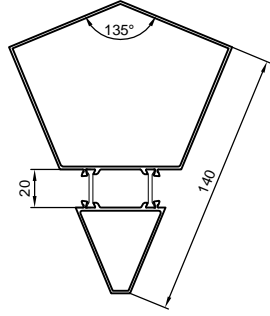
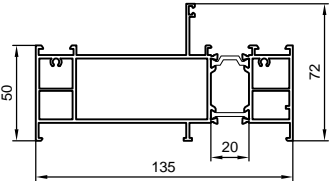
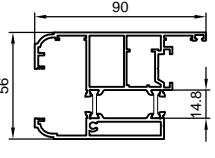
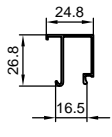
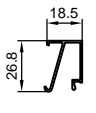
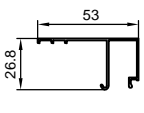
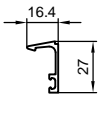
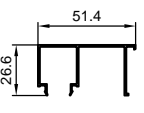
<b>JM101</b>	JM1011	JM1012	<b>JM102</b>		JM1021	JM1022	
	窗框		中挺	1.80	2.657kg/m		
1.80	2.201kg/m						
活动角码或JX101							
<b>JM103</b>	JM1031	JM1032	<b>JM104</b>		JM1041	JM1042	
	转角		转角	1.40	2.064kg/m		
1.80	3.681kg/m						
活动角码或JX101							
<b>JM105</b>	JM1051	JM1052					
	窗框						
1.80	2.792kg/m						
活动角码或JX101							
<b>JM201</b>	JM2011	<b>JM202</b>			<b>JM203</b>	JM2031	
	外开窗扇	纱扇	1.80	1.386kg/m	窗扇		
1.80	2.102kg/m			1.80	2.119kg/m		
活动角码	JM2012	活动角码或JX101			活动角码	JM2032	
<b>JM204</b>	JM2041	<b>JM205</b>			<b>JK303</b>		
	窗扇假中挺	纱扇假中挺	1.40	0.680kg/m	压线		
1.40	1.166kg/m			1.00	0.233kg/m		
活动角码	JM2042				槽口26.7		
<b>JM301</b>			<b>JM302</b>			<b>JM303</b>	
	压线		压线	1.00	0.206kg/m	反压线	
1.00	0.219kg/m				1.00	0.317kg/m	
槽口33		槽口40			槽口26		
<b>JM304</b>			<b>JM305</b>			<b>JM306</b>	
	纱压线		压盖	1.00	0.499kg/m	反压线	
1.40	0.230kg/m				1.00	0.372kg/m	
槽口4.8					槽口27		

# 76JQ系列隔热平开门、窗结构图

内开门

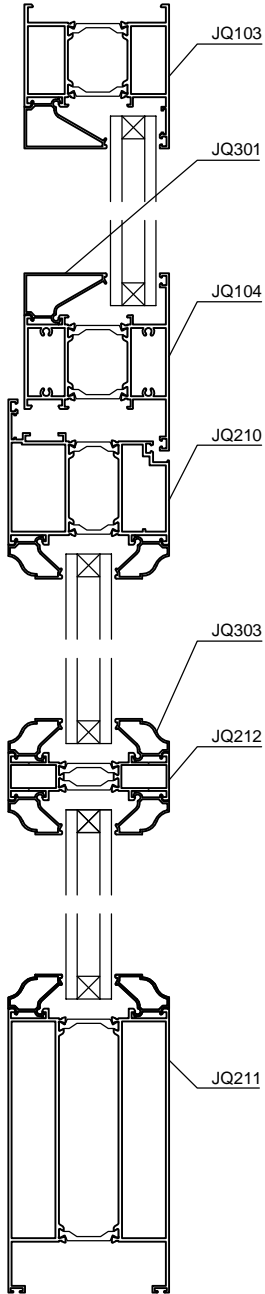

内开窗

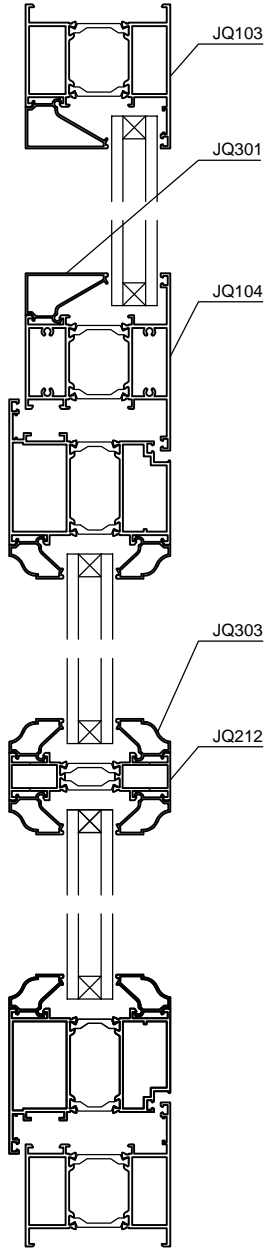

外开窗

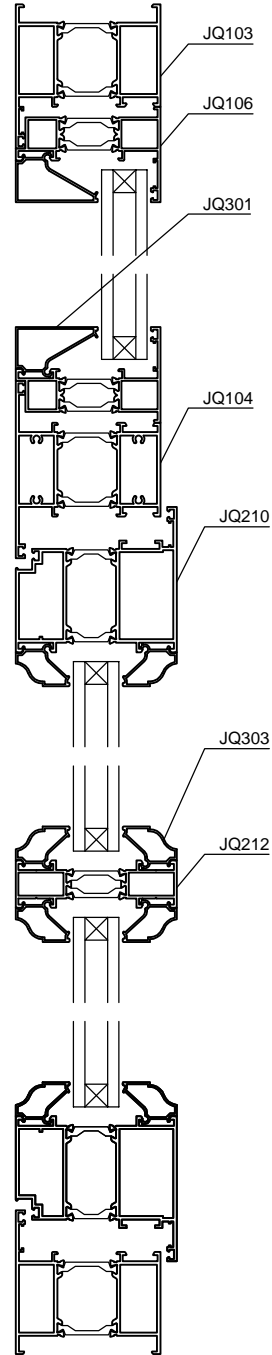

# 76JQ系列隔热平开门、窗型材图

<b>JQ103</b> 门框 1.80 1.871kg/m 角码JX102	JL1031 JL1032 	<b>JQ104</b> 门中挺 1.80 2.113kg/m	JL1041 JL1042 	<b>JQ106</b> 转换框 1.40 1.175kg/m 角码JX101	JL1061 JL1062 
<b>JQ109</b> 拼接件 1.20 0.898kg/m	JL1091 	<b>JQ203</b> 内开门扇 1.80 2.316kg/m 角码JX104	JL2031 JL2032 	<b>JQ204</b> 外开门扇 1.80 2.314kg/m 角码JX104	JL2041 JL2042 
<b>JQ205</b> 门中横 1.80 3.158kg/m	JL2051 JL2052 	<b>JQ206</b> 门下横 1.80 3.659kg/m	JL2061 JL2062 		
<b>JQ207</b> 假中挺 1.40 1.342kg/m	JL2071 JL2072 	65JL系列改穿加宽隔热条生成76JQ系列。 SMC314替换SMC200、SMI200 SMC262替换SMC148、SMI148			
<b>JQ210</b> 内外开扇 1.80 2.139kg/m 角码JX104	JL2031 JL2042 	<b>JQ211</b> 门下横 1.80 3.576kg/m	JQ2111 		
<b>JQ212</b> 扇中格 1.40 1.172kg/m	JQ2121 	<b>JQ301</b> 28直角压线 1.00 0.346kg/m 槽口28		<b>JQ302</b> 35直角压线 1.00 0.310kg/m 槽口35.2	
<b>JQ303</b> 圆角扇压线 1.00 0.239kg/m 槽口28		<b>JQ304</b> 辅助压线 1.00 0.168kg/m		<b>JQ305</b> 连接件 3.00 0.803kg/m	

THE QIYE  
KAITU  
QIYEXILIEHUACE

吴江市永亨铝业有限公司

地 址：江苏省苏州市吴江区七都镇心田湾工业区

电 话：0512-63801858-1

传 真：0512-63801953-3

<http://www.yonghenglvye.com/>